

Quadrant's Machinist Handbook



QUADRANT

You inspire ... we materialize®

The World's Leading Manufacturer of Plastic Stock Shapes

Plastics increasingly replace traditional materials such as bronze, stainless steel, cast iron and ceramics. They are chosen for improved performance and cost reduction. Plastics can:

- **Reduce Weight**
- **Eliminate Corrosion**
- **Improve Wear Performance in Unlubricated Conditions**
- **Reduce Noise**
- **Increase Part Life**
- **Insulate, both Thermally and Electrically**

Typical applications for engineering plastics range from semiconductor processing equipment components to heavy equipment wear parts, to food processing industry components.

Machinable plastic stock shapes (sheet, rod, and tube) are now available in more than 50 grades, spanning the performance/price range of both ferrous and non-ferrous metals to specialty ceramics. Plastics capable of long term service up to 300°C, with short term exposures to 500°C are now available. As the number of material options has increased, so has the difficulty of selecting the right material for a specific application.

TABLE OF CONTENTS

Coolants	5
Annealing	6
Machinability	9
Drilling	10
Sawing	16
Milling	19
Turning	21



The following guidelines are presented for those machinists not familiar with the machining characteristics of plastics. They are intended as guidelines only, and may not represent the most optimum conditions for all parts. The troubleshooting quick reference guides in this booklet should be used to correct undesirable surface finishes or material responses during machining operations. All Quadrant materials are stress relieved to ensure the highest degree of machinability and dimensional stability. Compared to metals, however, the higher coefficient of thermal expansion, lower stiffness and higher elasticity as well as eventual swelling due to moisture absorption (mainly with nylons) and possible deformations caused by internal stress-relieving during and after machining, generally result in greater difficulty maintaining tight tolerances during and after machining. A good rule of

thumb for machining tolerances on plastics is 0.1 to 0.2% of the nominal size although tighter tolerances are possible with very stable, reinforced materials.

Quadrant Engineering Plastic Products' stock shapes can be easily machined on ordinary metalworking and in some cases on woodworking machines. However, there are some points which are worth noting to obtain improved results.

In view of the poor thermal conductivity, relatively low softening and melting temperatures of thermoplastics, **generated heat must be kept to a minimum** and heat build up in the plastics part avoided. This is in order to prevent deformations, stresses, colour changes or even melting.

Therefore:

- Tools must be kept sharp and smooth at all times (ground cutting edges),
- Feed rates should be as high as possible,
- Tools must have sufficient clearance so that the cutting edge **only** comes in contact with the plastic material,
- A good swarf removal from the tool must be assured,
- Coolants should be applied for operations where plenty of heat is generated (e.g. drilling).

When machining Quadrant stock shapes, remember...

- Thermal expansion is up to 20 times greater with plastics than with metals.
- Plastics lose heat more slowly than metals, so avoid localized overheating.
- Softening (and melting) temperatures of plastics are much lower than those of metals.
- Plastics are much more elastic than metals.

Because of these differences, you may wish to experiment with fixtures, tool materials, angles, speeds and feed rates to obtain optimum results.

GETTING STARTED

- As engineering plastics are not as rigid as metals, it is essential to support the work adequately during machining in order to prevent deflection or deformation.
- High speed steel tools work well with many plastics.
- For long runs, use tungsten carbide, ceramic or polycrystalline diamond tooling.
- Polycrystalline diamond tooling provides optimum surface finish when machining celazole® pbi or torton® pai.

- Except for drilling and parting, coolants are not typically necessary for thermoplastic machining operations.
- Keeping the cutting area cool generally improves surface finish and tolerances.
- When coolants are required, water-soluble coolants generally do very well. They should, however, not be used when machining amorphous thermoplastics, such as PC 1000, RADEL[®] PPSU 1000, ULTEM[®] PEI 1000, PSU 1000 and SEMITRON[®] ESd 410C, because these materials are susceptible to environmental stress-cracking. The most suitable coolants for these materials are pure water or compressed air.
- When the use of water-soluble coolants or general purpose petroleum based cutting fluids cannot be avoided during the machining of amorphous thermoplastics (e.g. during drilling of large diameters and/or deep holes or during tapping operations), the parts should immediately after machining be thoroughly cleaned with isopropyl alcohol first and rinsed with pure water afterwards in order to reduce the risk of stress-cracking.

Annealing

Quadrant Engineering Plastic Products' stock shapes are annealed using a proprietary stress-relieving cycle to minimise any internal stresses that may result from the manufacturing process.

This annealing procedure generally assures optimum dimensional stability during and after machining. However, when machining parts that have to meet stringent requirements with respect to dimensional stability (tolerances, distortion, warpage,...) and/or when machining causes asymmetric and/or heavy section changes, it is recommended to apply an intermediate annealing procedure after pre-machining and prior to final machining of the part.

Annealing can be done in an air or preferably a nitrogen circulating oven, or in an oil bath.

Recommended annealing

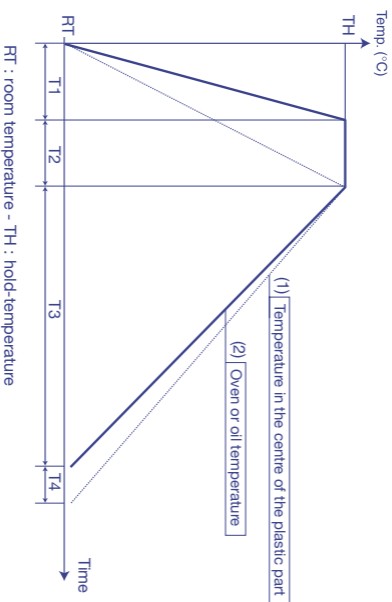

T1: heat-up time (heating rate: 10 – 20°C/hour)

T2: hold-time (depends on the wall thickness: 10 minutes per mm part thickness)

T3: cool-down time (cooling rate: 5 – 10°C/hour)

T4: additional time required to establish normal room temperature (depends on the wall thickness: 3 minutes per mm part thickness)

TIPS FOR ANNEALING

- When pre-machining, leave enough oversize to allow machining to final sizes after annealing.
- Fixturing parts to desired shape or flatness during the entire annealing cycle often proves advantageous.
- Do not unfixture until parts have completed entire annealing cycle and are cool to the touch.
- Make sure that temperatures are uniform and within +/- 3°C all over the oven or the oil bath at all times during the annealing cycle.
- Do not take short-cuts.

Annealing guidelines

Materials	Heat up	Hold temperature	Hold-time (T2)	Cool Down	Environment(*)
PA	10-20 °C/h	150°C	10 min/mm	5-10°C/h	air, nitrogen or oil
POM	10-20 °C/h	150°C	10 min/mm	5-10°C/h	air, nitrogen or oil
PET	10-20 °C/h	150°C	10 min/mm	5-10°C/h	air, nitrogen or oil
PE-(U)HMW	10-20 °C/h	80°C	10 min/mm	5-10°C/h	air, nitrogen or oil
PC	10-20 °C/h	130°C	10 min/mm	5-10°C/h	air or nitrogen
PEEK	10-20 °C/h	250°C	10 min/mm	5-10°C/h	air, nitrogen or oil
PPS	10-20 °C/h	200°C	10 min/mm	5-10°C/h	air, nitrogen or oil
PPSU	10-20 °C/h	200°C	10 min/mm	5-10°C/h	air or nitrogen
PEI	10-20 °C/h	200°C	10 min/mm	5-10°C/h	air or nitrogen
PSU	10-20 °C/h	170°C	10 min/mm	5-10°C/h	air or nitrogen
PVDF	10-20 °C/h	140°C	10 min/mm	5-10°C/h	air, nitrogen or oil

(*): when annealing in air, a more or less pronounced colour change of the outer surface is to be expected (particularly with nylons) – the thin oxidised surface-layer involved, however, is most of the time removed during further machining operations.

Machinability

Relative Machinability (1 to 6 ; 1 = easiest)

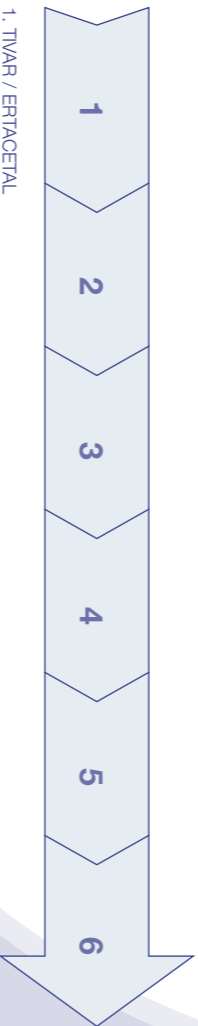

1. TIVAR / ERTACETAL
2. ERTALON & NYLATRON GRADES / SYMALIT PVDF 1000 / FLUOROSINT 207 & 500
3. ERTALYTE / ERTALYTE TX / KETRON PEEK-1000 / TORLON 4203 & 4503 PAI / PC 1000 / RADEL PPSU 1000 / ULTEM PEI 1000 / PSU 1000
4. ERTALON 66-GF30 / TECHTRON HPV PPS / KETRON PEEK-HPV / TORLON 4301 & 4501 PAI
5. KETRON PEEK-GF30 / KETRON PEEK-CA30 / TORLON 5530 PAI
6. CELAZOLE PBI

Drilling

Plastics can build up heat very easily during drilling operations, especially when hole depths are greater than twice the diameter. Therefore a cooling liquid is generally recommended.

- Small diameter holes (0.5 - 25 mm diameter)
High speed steel twist drills generally work well. In order to improve heat and swarf removal, frequent pull-outs (peck-drilling) are necessary. A slow spiral (low helix) drill will allow for better swarf removal.
- Large diameter holes (25 mm diameter and larger)
It is advised to use drills with a thinned web (dubbed drill) in order to reduce friction and hence heat generation.
Drill large holes stepwise: a bore diameter of 50 mm e.g. should be made by drilling successively with \varnothing 12 mm and \varnothing 25 mm, then by expanding the hole further with large diameter drills or with a single point boring tool.



For the following materials it is recommended to bore holes in round rods on a lathe, using "insert drills" or a rigid, flat boring tool with its cutting edge perfectly set on centre-height (see drawing on the right).

- Rods > 50 mm diameter:
CELAZOLE® PBI, TORLON® PAI, KETRON® PEEK-HPV, KETRON® PEEK-GF30, KETRON® PEEK CA30, TECHTRON® HPV PPS and SEMITRON® ESD 410C.
- Rods > 100 mm diameter:
ERTALON® 66-GF30, ERTALYTE®, ERTALYTE® TX and KETRON® PEEK-1000.
- Rods > 200 mm diameter:
ERTALON® and NYLATRON®.

Note: for these materials, some machinists prefer to heat the stock shapes up to about 120 - 150°C prior to drilling.

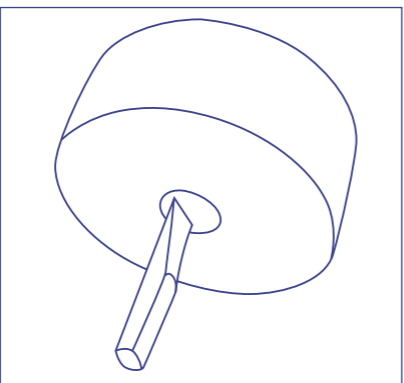

Drilling

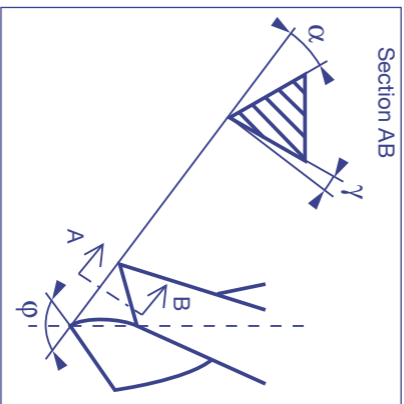

12

α : relief angle
 γ : rake angle
 ϕ : top angle
 v : cutting speed
 s : feed

(°)
(°)
(°)
(m/min)
(mm/rev.)



	α	γ	ϕ	S	V
ERTALON / NYLATRON • TIVAR • SYMALIT PVDF 1000	10-15	3-5	90-120	0.1-0.3	50-100
ERTACETAL • SEMITRON ESD 225	5-10	3-5	90-120	0.1-.03	50-100
ERTALYTE • TORLON 4203 / 4503 PAI KETRON PEEK-1000	5-10	3-5	90-120	0.1-0.3	50-80
PC 1000 • RADEL PPSU 1000 • ULTEM PEI 1000 • PSU 1000	5-10	3-5	90-120	0.1-0.3	50-100
ERTALON 66-GF30 • TORLON 4301 / 4501 / 5530 PAI • KETRON PEEK-HPV / GF30 / CA30 • TECHTRON HPV PPS • SEMITRON ESD 410C / 520 HR	5-10	3-5	90-120	0.1-0.3	50-80
CELAZOLE PBI	5-10	3-5	90-120	0.1-0.3	25-50
FLUOROSINT 207 / 500 • SEMITRON ESd 500 HR	5-10	3-5	90-120	0.1-0.3	50-100

Drilling - Troubleshooting

Difficulty	Tapered Hole	Burned or Melted Surface	Chipping of Surfaces	Chatter	Feed Marks or Spiral Lines on Inside Diameter	
Common Cause	<ol style="list-style-type: none">1. Incorrectly sharpened oil2. Insufficient clearance3. Feed too heavy	<ol style="list-style-type: none">1. Wrong type drill2. Incorrectly sharpened oil3. Feed too light4. Web too thick	<ol style="list-style-type: none">1. Feed too heavy2. Clearance too great3. Too much rake (thin web as described)	<ol style="list-style-type: none">1. Too much clearance2. Feed too light3. Drill overhang too great4. Too much rake (thin web as described)	<ol style="list-style-type: none">1. Feed too heavy2. Drill not centered3. Drill ground off-center	

Oversize Holes	Undersize Holes	Holes Not Concentric	Burr at Cut-off	Rapid Dulling of Drill
<ol style="list-style-type: none"> 1. Drill ground off-center 2. Web too thick 3. Insufficient clearance 4. Feed rate too heavy 5. Point angle too great 	<ol style="list-style-type: none"> 1. Dull drill 2. Too much clearance 3. Point angle too small 	<ol style="list-style-type: none"> 1. Feed too heavy 2. Spindle speed too slow 3. Drill enters next piece too far 4. Cut-off tool leaves nib, which deflects drill 5. Web too thick 6. Drill speed too heavy at start 7. Drill not mounted on center 8. Drill not sharpened correctly 	<ol style="list-style-type: none"> 1. Dull cut-off tool 2. Drill does not pass completely through piece 	<ol style="list-style-type: none"> 1. Feed too light 2. Spindle speed too fast 3. Insufficient lubrication from coolant

Sawing

Proper clamping of shapes on worktable is required to avoid vibrations and consequent rough cutting or even rupture.

Band saws, circular saws or reciprocating saws need to have widely spaced teeth, to assure good chip removal. They should have enough set to minimize the friction between the saw and the work and also to avoid close-in behind the cutting edge, causing excessive heat build-up and even blocking of the saw.

IMPORTANT:

Reinforced materials such as ERTALON® 66-GF30, TORLON® 4301 PAI, TORLON® 4501 PAI, TORLON® 5503 PAI, KETRON® PEEK-HPV, KETRON® PEEK-GF30, KETRON® PEEK-CA30, TECHTRON® HPV PPS, SEMITRON® ESd 410C and SEMITRON® ESd 520HR are preferably cut with a brand saw which has a tooth pitch of 4 to 6 mm (CELAZOLE® PBI: 2-3 mm). Do not use circular saws, as this usually leads to cracks.

SAWING TIPS

- Tungsten carbide tipped saw blades wear well and provide optimum surface finishes ; particularly alternate top bevel and triple chip grinds yield smooth cuts with little or no chipping or burrs.

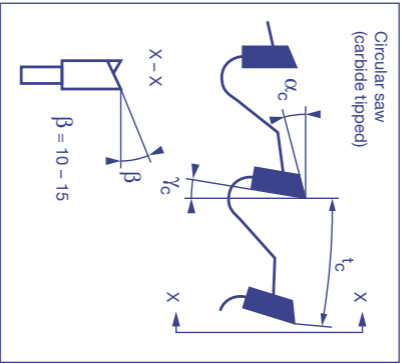

c : circular saw
b : band saw

α : relief angle (°)
 γ : rake angle (°)
t : pitch (mm)
v : cutting speed (m/min)

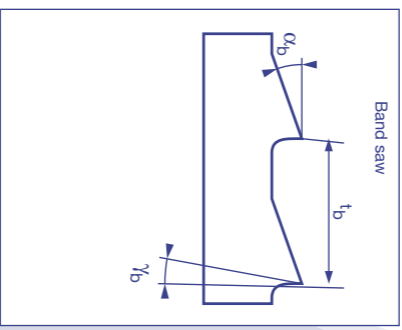

	α_c	γ_c	t_c	V_c	α_b	γ_b	t_b	V_b
ERTALON / NYLATRON • TIVAR • SYMALIT PVDf 1000	10 - 15	0 - 15	8 - 45	1,000-3,000	25 - 40	0 - 8	4 - 10	50 - 500
ERTACETAL • SEMITRON ESD 225	10 - 15	0 - 15	8 - 45	1,000-3,000	25 - 40	0 - 8	4 - 10	50 - 500
ERTALYTE • TORLON 4203 / 4503 PAI KETRON PEEK-1000	10 - 15	0 - 15	8 - 25	1,000-3,000	25 - 40	0 - 8	4 - 10	50 - 400
PC 1000 • RADEL PPSU 1000 • ULTEM PEI 1000 • PSU 1000	10 - 15	0 - 15	8 - 25	1,000-3,000	25 - 40	0 - 8	4 - 10	50 - 400
ERTALON 66-GF30 • TORLON 4301 / 4501 / 5530 4501 / 5530 PAI • KETRON PEEK-HPV / GF30 / CA30 • TECHTRON HPV PPS • SEMITRON ESD 410C / 520 HR	10 - 15	0 - 15	8 - 25	1,000-3,000	25 - 40	0 - 8	4 - 6	50 - 200
CELAZOLE PBI	10 - 15	0 - 15	8 - 25	1,000-3,000	25 - 40	0 - 8	2 - 3	25 - 100
FLUOROSINT 207 / 500 • SEMITRON ESD 500HR	10 - 15	0 - 15	8 - 25	1,000-3,000	25 - 40	0 - 8	4 - 6	50 - 200

Two flute end mills, face mills and shell mills with inserts as well as fly cutters can be used for milling thermoplastics.

Climb milling is recommended to help reduce heat by dissipating it into the chip, and melting and poor surface finishes are minimized.

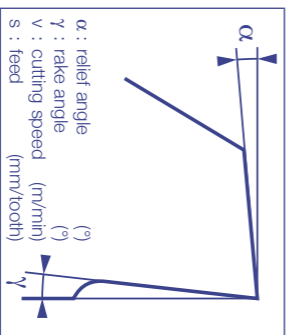

MILLING TIP

- Thin workpieces are often fixed onto the work table by means of suction plates or double-sided adhesive tape.

Climb Milling vs. Conventional Milling

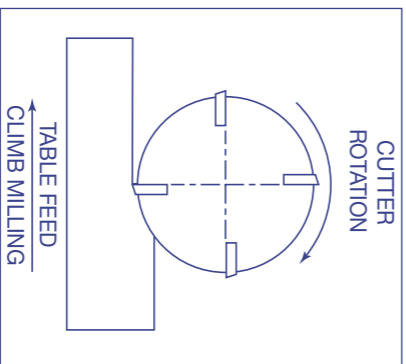

VS.

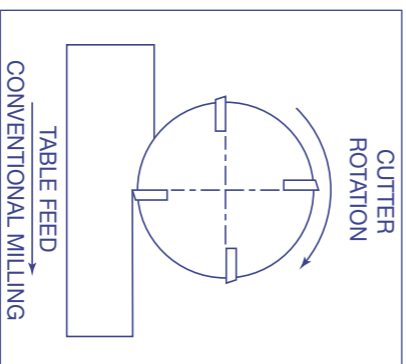

Typical turning tool with tungsten carbide insert

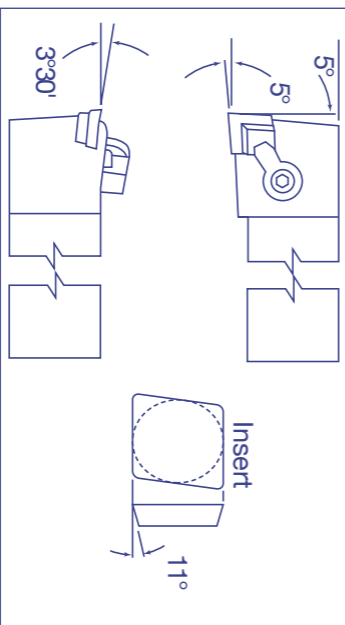

TURNING TIP

- The continuous chip stream produced when turning and boring many thermoplastics can be handled well using a compressed air powered suction system (directly disposing the swarf onto a container), in this way avoiding the chip wrapping around the chuck, the tool or the workpiece.

Turning & Boring Troubleshooting

Difficulty	Melted Surface	Rough Finish	Burrs at Edge of Cut	Cracking or Chipping of Corners	Chatter
Common Cause	<ol style="list-style-type: none">1. Tool dull or heel rubbing2. Insufficient side clearance3. Feed rate too slow4. Spindle speed too fast	<ol style="list-style-type: none">1. Feed too heavy2. Incorrect clearance angles3. Sharp point on tool (slight nose radius required)4. Tool not mounted on center	<ol style="list-style-type: none">1. No chamfer provided at sharp corners2. Dull tool3. Insufficient side clearance4. Lead angle not provided on tool (tool should ease out of cut gradually, not suddenly)	<ol style="list-style-type: none">1. Too much positive rake on tool2. Tool not eased into cut (tool suddenly hits work)3. Dull tool4. Tool mounted below center	<ol style="list-style-type: none">1. Too much nose radius on tool2. Tool not mounted solidly3. Material not supported properly4. Depth of cut too heavy (use 2 cuts)

Parting (Cutting-off) - Troubleshooting

Difficulty	Melted Surface	Rough Finish	Spiral Marks	Concave or Convex Surfaces	Nibs or Burrs at Cut-off Point	Burns on Outside Diameter
Common Cause	<ol style="list-style-type: none"> 1. Dull tool 2. Insufficient side clearance 3. Insufficient coolant supply 	<ol style="list-style-type: none"> 1. Feed too heavy 2. Tool improperly sharpened 	<ol style="list-style-type: none"> 1. Tool rubs during its retreat 2. Burr on point of tool 	<ol style="list-style-type: none"> 1. Point angle not great enough 2. Tool not perpendicular to spindle 3. Tool deflecting 4. Feed too heavy 5. Tool mounted above or below center 	<ol style="list-style-type: none"> 1. Point angle not great enough 2. Dull tool 3. Feed too heavy 	<ol style="list-style-type: none"> 1. No chamfer applied before cut-off 2. Dull tool

Turning

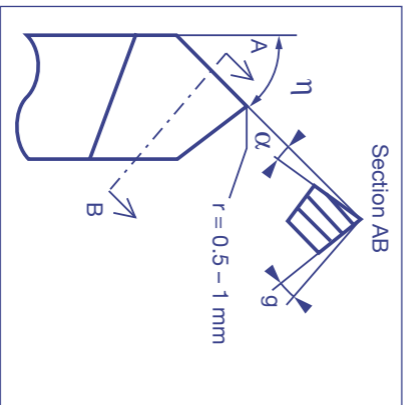

- α : side relief angle (°)
- γ : rake angle (°)
- η : side cutting edge angle (°)
- v : cutting speed (m/min)
- s : feed (mm/rev.)

	α	γ	η	S	V
ERTALON / NYLATRON • TVAR • SYMALIT PVDF 1000	5-15	0-10	0-45	0.05-0.5	200-500
ERTACETAL • SEMITRON ESD 225	5-15	0-10	0-45	0.05-.05	200-500
ERTALYTE • TORLON 4203 / 4503 PAI KETRON PEEK-100	5-15	0-10	0-45	0.05-0.5	200-400
PC 1000 • RADEL PPSU 1000 • ULTEM PEI 1000 • PSU 1000	5-15	0-10	0-45	0.05-0.4	200-400
ERTALON 66-GF30 • TORLON 4301 / 4501 / 5530 PAI • KETRON PEEK-HPV / GF30 / CA30 • TECHTRON HPV PPS • SEMITRON ESD 410C / 520 HR	5-15	0-10	0-45	0.05-0.3	100-200
CELAZOLE PBI	5-10	3-5	0-45	0.05-0.2	25-100
FLUOROSINT 207 / 500 • SEMITRON ESD 500 HR	8-12	0-5	0-45	0.08-0.4	150-400



Regional Headquarters

EUROPE

Quadrant EPP AG
Hardstrasse 5
CH-5600 Lenzburg
Tel +41 (0) 62 8858409
Fax +41 (0) 62 8858181
e-mail: europe.epp@qplas.com

NORTH AMERICA

Quadrant EPP USA, Inc.
2120 Fairmont Avenue
PO Box 14235 - Reading, PA 19612-4235
Tel 800 366 0300 / +1 610 320 6600
Fax 800 366 0301 / +1 610 320 6868
e-mail: americas.epp@qplas.com

ASIA-PACIFIC

Quadrant EPP Asia Pacific Ltd
108 Tai To Tsuen, Ping Shan
Yuen Long - N.T. Hong Kong
Tel +852 (0) 24702683
Fax +852 (0) 24789966
e-mail: asia.epp@qplas.com

All statements, technical information and recommendations contained in this publication are presented in good faith, based upon tests believed to be reliable and practical field experience. The reader is cautioned, however, that Quadrant Engineering Plastic Products does not guarantee the accuracy or completeness of this information and it is the customer's responsibility to determine the suitability of Quadrant's products in any given application. ERTALON®, NYLATRON®, ERTACETAL®, ERTALYTE®, TIVAR®, KETRON®, TECHTRON®, SYMALT® and FLUOROSINT® are registered trademarks of the Quadrant Group. TORLON® and RADEL® are registered trademarks of Solvay Advanced Polymers. ULTEM® is a registered trademark of GE Plastics. CELAZOLE® is a registered trademark of PBI Performance Products Inc. The guide was created by Quadrant Engineering Plastic Products. Design and content are protected by copyright law. © 2006 Quadrant Engineering Plastic Products

Visit our website for additional information: www.quadrantplastics.com